

No:

SB204-21

Date:

12/03/21

Issue:

1

Subject:

Elite 6 Engine ECU Mount Improvement

It is possible on the Elite 6 for debris e.g. stones to make their way into the area behind the engine ECU. If the stones do not work their way out it is possible for them to rub through ECU causing irreparable damage.

To overcome this problem a simple fix is in place to space the lower rubber mounts out by adding 6mm spacers and longer bolts, production vehicles leaving DE are to this standard.

Fig. 1 below shows the position of the engine ECU and the spacer positioning.

Fig. 1

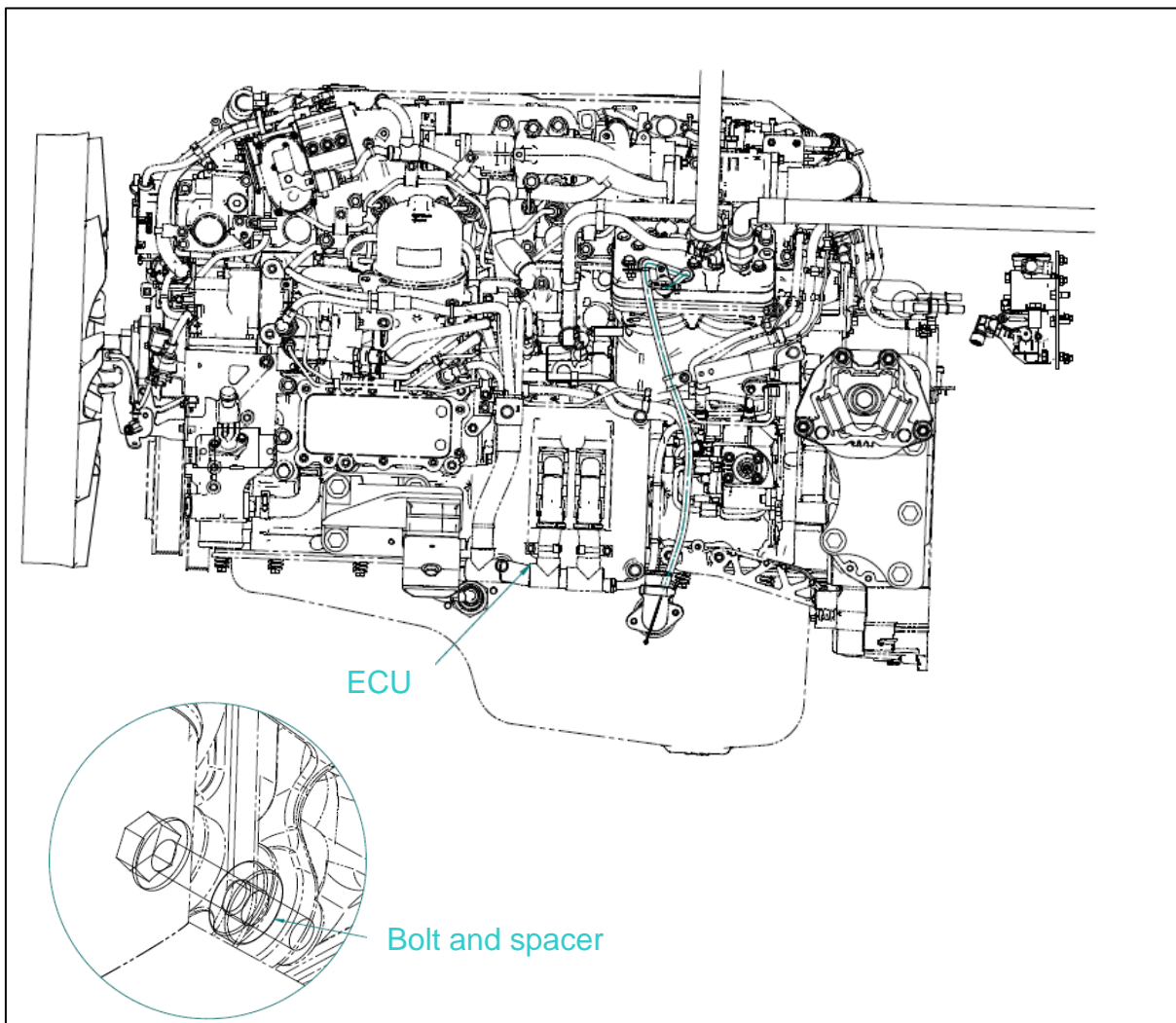

No:

SB204-21

Date:

12/03/21

Issue:

1

Subject:

Elite 6 Engine ECU Mount Improvement

Fig. 2 shows the spacers mounted.

Fig. 2

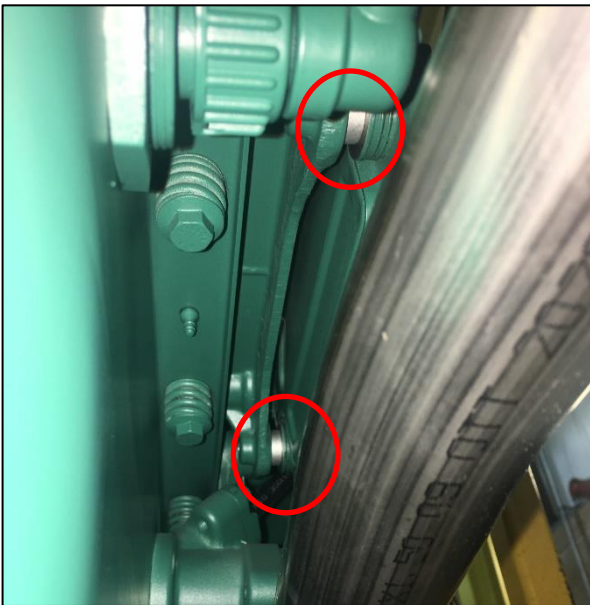

Bolts should be torqued to 25 Nm.

To apply this upgrade order part number SL1277 from DE parts on 01926 458555.