

# Phoenix High Capacity TwinPack

EURO 5i - WIDE TRACK 70 / 30 Split

# Euro 5i

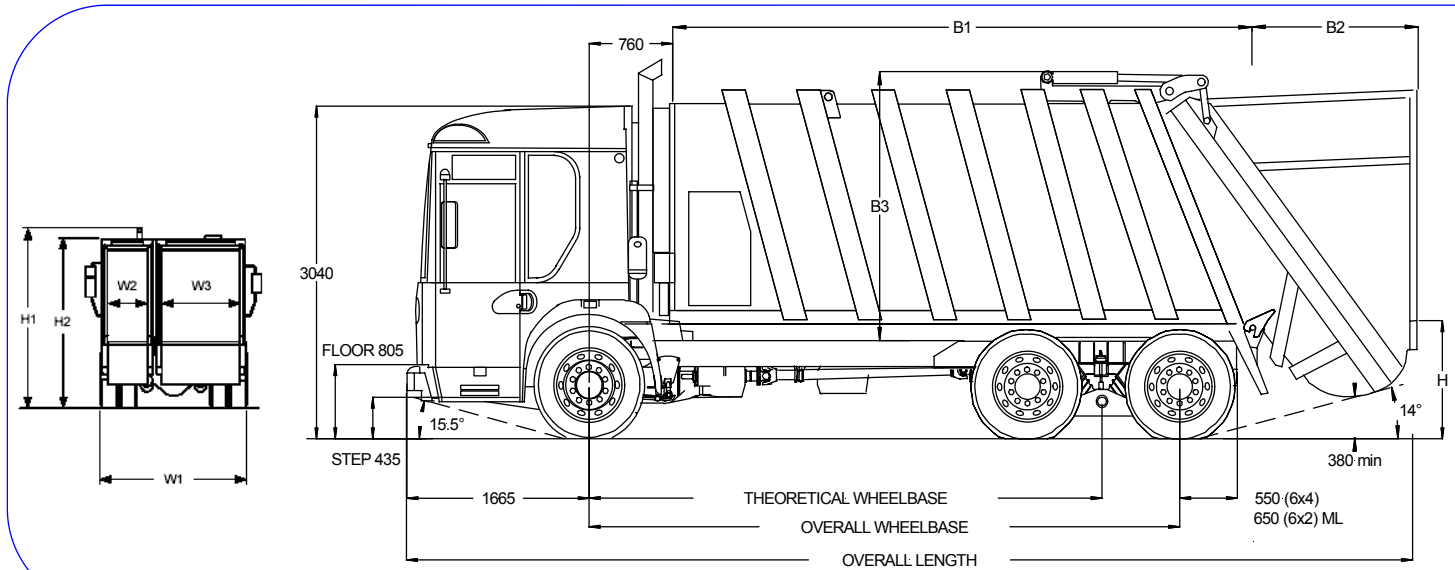

HCTP 20 shown, mounted on Dennis Eagle Elite 2 - 6x4

Phoenix Body Type / Volume		TwinPack 15	TwinPack 20
Elite 2 Chassis type		6x2 Mid Lift	6x4
GVW		23000	26000*
Unladen weight		13720	15120
Overall wheelbase		4250	5400
Theoretical wheelbase		3795	4700
Axle 2 to 3 bogie spread		1220	1385
Overall length (open-back hopper)		8205	9305
Overall length - tailgate raised (open-back hopper)		9070	10170
Front axle to front of body		Minimum 730	
Front overhang		1665	
Rear overhang (open-back hopper)		2185	2185
Rear overhang - tailgate raised (open-back hopper)		3050	3050
Overall width	W1	2530	2530
Width inside tailgate - small hopper	W2	685	685
Width inside tailgate - large hopper	W3	1385	1385
Overall height - tailgate raised		5250	5300
Overall height - exhaust tip (nominal)	H1	3525	3525
Overall height to top of tailgate lift cylinders	H2	3230	3280
Manual loading height	H	1100	1150
Body floor length	B1	4280	5320
Tailgate length	B2	1500	1500
Body height from chassis	B3	2140	2140
Turning Circle - metres (a)		15.6	20.6*
Ground clearance - front (Front Under-Run Protection fitted)		360	
Ground clearance - rear		380	400
Approach angle		15°	
Departure angle		14°	

(a) Turning circles quoted are kerb-to-kerb with standard tyres, for wall-to-wall figures add 1600mm.  
\* Front axle plating of 8000 kgs required for 6x4 HCTP 20

NOTE: Unless otherwise stated, all dimensions are nominal, in mm and represent an unladen condition. All specifications are subject to manufacturers tolerances. An allowance of +/- 2% should be made for all weights. All weights are in kgs and include AdBlue, 50 litres of fuel, oil and water. Additional equipment may alter dimensions and weights quoted. Weight data is based on Volvo D7E engine and Allison MD3000 series gearbox.



# Phoenix High Capacity TwinPack

EURO 5i - WIDE TRACK 70 / 30 Split

# Euro 5i

## Body

- The Phoenix High Capacity Twin Pack has 2 totally separate body air spaces constructed from high tensile steel and braced by hoops, with two rolled steel longitudinal channels under the floor.
- The body is divided longitudinally to give the following capacities:-

Size	15	20
Small compartment capacity (m <sup>3</sup> )	5.0	6.3
Large compartment capacity (m <sup>3</sup> )	10.0	12.6

## Tailgate

- Two totally independent tailgates.
- Low ravel rail height for manual loading and versatile binlift mounting.
- Sides and floor manufactured from high tensile abrasion resistant steel.
- Substantial pressed side plates form integrated channels to guide the packing mechanism.
- Heavy duty automatic body locks.
- Integral body seals fitted to prevent liquid leakage from bottom edge and lower sides.
- Integral tailgate props.

Size	Narrow	Wide
Swept volume capacity (m <sup>3</sup> )	0.62	1.24

## Packing Mechanism

- Totally independent two-plate packer / sweeper design.
- Manufactured using high tensile abrasion resistant steel.
- Strong box-girder construction.
- Sweeper plate pivots on heavy duty phosphor-bronze bearings.
- Slides within hopper channels on low friction self lubricating bearings.

## Refuse Ejection Barrier

- Separate ejection barriers.
- Barrier face is manufactured from high tensile abrasion resistant steel, forming a smooth discharge surface.
- Phosphor bronze bearings guide the barrier along rails within the body.
- Multi-staged double acting hydraulic cylinders, enable efficient ejection and retraction.

## Electrical System

- Independent electrical logic systems.
- Control printed circuit boards housed in weatherproof boxes, at rear and sides of vehicle.
- Switches and control stations are high quality sealed items.
- Number and colour coded wiring for easy identification, maintenance and fault finding.
- Weatherproof switch, plug and socket connectors.
- Circuit designed to enhance Health and Safety features, and installation of binlifts. (EN1501-I compliant)

## Hydraulic Systems

- PTO mounted pump delivers 0.9 litres/second at c. 1200 rpm, to each independent hydraulic system.
- Full flow 12 micron pressure filter controls contaminant levels in each system.
- Engine speed is maintained via a second throttle when hydraulic power consumption increases.
- Four-spool electro-pneumatic operated valve controls all system functions.
- Main valves housed on valve trays, under the section of the body they control, these can be replaced as complete units.
- All cylinders are double acting with hard chromed rods for long life.

## Safety

-  Approved. Safe by design.
- Low bodywork minimises risk of roll-over when asymmetrically loaded.
- Two-plate design, automatic body locks and clean discharge remove the need to approach moving parts.
- Interlocks prevent the mechanism from working unless the tailgates are fully lowered into their locks.
- Automatic gearbox interlocks enhance safe operations.
- Hopper lift rams are fitted with integral pilot operated load holding valves so that even if a hose fails, or is removed, the hopper cannot descend unless positively powered downwards.
- Integral mechanical props for safely supporting the hopper during maintenance operations.
- In cab audio / visual "tailgate raised" warning.
- Illuminated external control stations.
- Interlocked access door for safe maintenance operations.

## Options

**For more details of specifications and options please consult a Dennis Eagle Sales representative.**

*Dennis Eagle Ltd. (the company) reserves the right to change the specification, design, material, procedures and dimensions of the vehicles described herein without prior notice at any time in the future, in accordance with the company's constant product improvement policy.*

DENNIS EAGLE LTD. Heathcote Way, Heathcote Industrial Estate, Warwick CV34 6TE. UK  
Tel: 00-44-(0)1926-316000 Fax: 00-44-(0)1926-316550 www.denniseagle.net sales@dennis-eagle.co.uk



**DENNIS EAGLE LTD**  
DESIGNED WITH YOU IN MIND

HCTP-e5i-1 08-10-07