

PHOENIX 2 - BODY RANGE

Built to perform



DENNIS EAGLE LTD
DESIGNED WITH YOU IN MIND

PHOENIX 2 - Built to perform

As Europe's leading provider of complete vehicle solutions for today's waste management industry, Dennis Eagle has designed and developed a highly versatile and functional body range that continues to set the standard for others to follow – PHOENIX 2.

With the capacity to cover every industry sector, the PHOENIX 2 body range - compatible with any make of chassis - features highly-engineered and premium quality products that are at home in many of the leading private and public sector fleets, both here in the UK and overseas. Continuing to prove itself on a daily basis across all operating conditions, it is a product range that is renowned for its rugged durability, outstanding technical performance and PHOENIX 2 has the ability to deliver competitive whole life costs.

Investment = Excellence

As with the Dennis Eagle Elite chassis, the current body range is the result of significant investment that has been made in product design, development and testing. Investment in production facilities to enable production of these new models has ensured that the Warwick manufacturing plant is truly an industry leader.

Designed on many years of experience and thorough in-house research, PHOENIX 2 is as innovative as its predecessor, launched over two and a half decades ago. It is a product that by its design redefines the RCV body concept. Using a high degree of component and assembly modularity, PHOENIX 2 has been designed to deliver the ultimate in durability, performance, reliability and efficiency.



PHOENIX 2 is packed with advanced features that deliver real benefits:

Curved smooth sided body

The cylindrical appearance of PHOENIX 2 not only delivers improved aesthetics but increases body capacity by 1 – 1½ m³ per body size. Manufactured from one piece rolled and pressed steel sides that extend body life and also increase the efficiency of the entire body concept and eliminate sign boards.



Keel shaped floor with inbuilt sump

In addition to increasing body strength, this design feature helps reduce one of the RCV industry's main problems - corrosion. The keel shape with floor channel and sump ensures that debris and liquids are collected and drained off effectively.



External pack rams

By operating out of the refuse collection area the possibility of the pack rams being damaged during operation is reduced. Being easier to access maintenance and servicing is made easier.



Externally located electrics

Positioning the electrics in a sealed unit on the side of the vehicle provides crucial protection from the elements and makes maintenance and servicing easier.



Roof mounted hopper lift rams

As well as enabling full height rubber seals to be used between the hopper and body, the new location of the hopper lift rams eliminates a potential trapping point for waste build up ahead of refuse being ejected.



Short rear overhang as standard

The 1.515 metre hopper length of PHOENIX 2 contributes to an increase in capacity but also reduces overall vehicle length thereby leading to greater efficiency whilst improving manoeuvrability.



Hydraulic pipe work roof mounted

Fixed to one side using sturdy fixings, access to all hydraulic pipe work is made easier as there is no need to work on top of the body.



PHOENIX 2 versatility

The PHOENIX 2 is the ultimate versatile body enabling any number of chassis and bin lift combinations to suit different requirements.

Easily mounted onto any conventional OEM chassis, the PHOENIX 2 works perfectly in conjunction with chassis types including DAF, Foden, Iveco, MAN, Mercedes, Scania, Seddon Atkinson and Volvo.

It is also compatible with all leading OEM bin lift systems such as Otto, Terberg and Zoeller, delivering genuine choice and flexibility.



Body specification

The standard 2.5m PHOENIX 2 product range is available in six body sizes. The narrow 2.23m PHOENIX 2 is offered in four different body sizes.

PHOENIX 2 Narrow

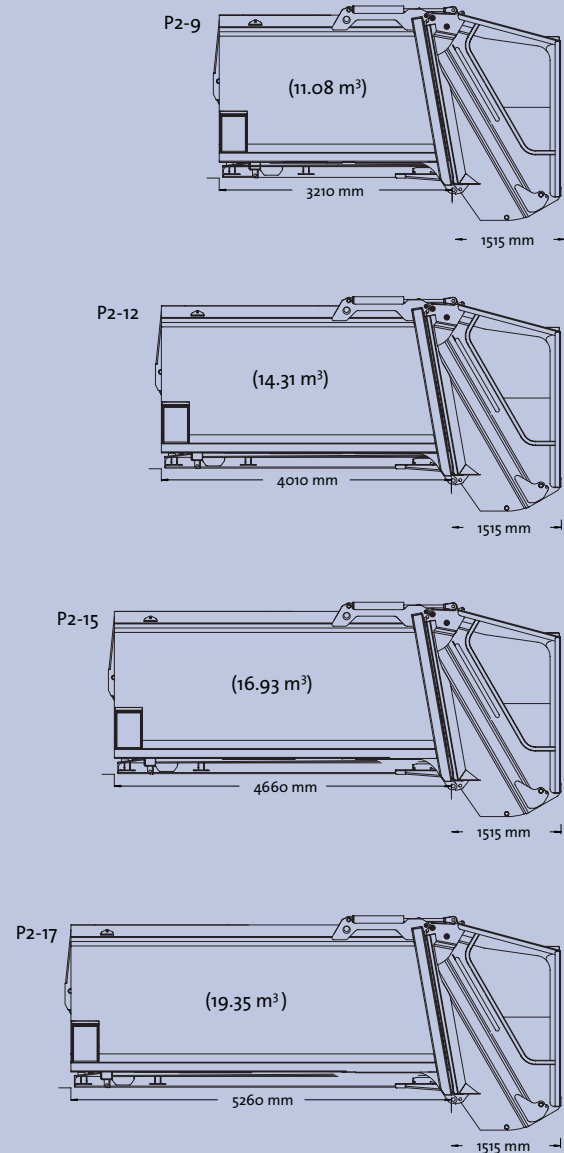

PHOENIX 2 Standard

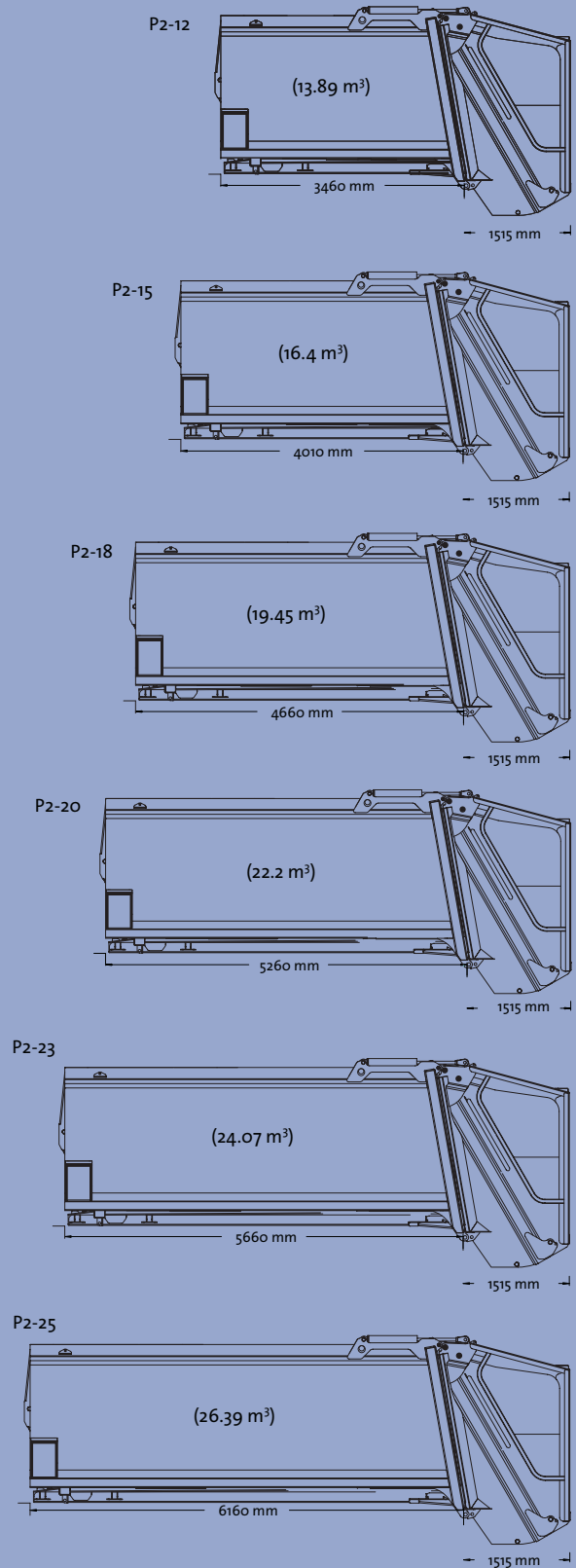

Individual detailed specification sheets available on request or from the Dennis Eagle website as downloadable pdf files.

Designed with you in mind

With a British engineering heritage that dates back to the turn of the last century, the company has become a UK market leader with a rapidly expanding customer base in Continental Europe, Scandinavia and the rest of the world.

Dennis Eagle designs and manufactures vehicles for people. It is the changing needs of our customer that drive our business and shape the way our vehicles look and perform.

By constantly monitoring the waste management industry and listening to what our customers say, nobody is more up to date with current environmental and safety issues, or better placed to provide solutions.

Our 600 strong team is extremely proud of the work it does and this is reflected in all aspects of our operation. We constantly strive to develop quality products that exceed expectation in terms of performance, cost and delivery.

Our vehicles really are designed with you in mind.



DENNIS EAGLE LTD
DESIGNED WITH YOU IN MIND

Dennis Eagle Limited
Heathcote Way
Heathcote Industrial Estate
Warwick CV34 6TE
Tel: +44 (0)1926 458500
Fax: +44 (0)1926 316550
Email: sales@dennis-eagle.co.uk

www.dennis-eagle.com