

BETA 2 BIN LIFTS

Heavy duty solutions



DENNIS EAGLE LTD
DESIGNED WITH YOU IN MIND

Designed with safety in mind

Dennis Eagle's new Beta 2 sets new standards in bin lift technology. Specifically designed to complement the popular Phoenix 2 RCV body range, the Beta 2 is ultimately versatile, ideal for trade use but equally suitable for heavy domestic collections.

Echoing the modular design of the Phoenix 2, the Beta 2 simply bolts on to the rear of the Phoenix 2 tailgate without the need for welding or adaptation.

What's more it is up to 30% lighter than most conventional split bin lifts as the Beta 2 does not require an adaptor frame and has a relatively short rear overhang. This results in a reduced effective rear axle load, delivering significant payload advantage.

The new Beta 2 has a lifting capacity of 500 kgs and can be supplied as a lip lift for wheeled bin operation or with

Paladin or DIN arms and features an automatic two-speed operation for optimum safety.

When you choose to buy Beta 2, you are buying much more than a binlift. A single point of contact will deliver spare parts and repairs for all Dennis Eagle body, chassis and binlift models featuring the same world class precision engineering, quality and reliability.



Features

1 Work lights

2 Rear view camera

Supplied within our standard specification.

3 Lip clamp

Heavy duty lip clamp designed for industrial use (rave shown in drop down position).

4 Rear lights

Fully compliant with UK traffic regulations (outline marker lights, high level lights and number plate lights). Strobe and rotating beacons available.

Light guard and joystick

Optional light guards can be fitted to avoid damage during operation. The joystick facilitates operation when locating wheeled bins.



5 Drop down rave

Can be lowered to 120cm for manual loading of large items and up to 140cm for continuous operation.

6 Multi-position bump bar

Designed to suit a wide range of bins and with skids for roll top container lid opening.

7 Paladin arms

In addition to the standard lip clamp paladin arms can be fitted with automatic bin sensor and clamping.



Controls

Ergonomically designed layout with heavy duty buttons to suit industrial operation.

Bin lift specifications

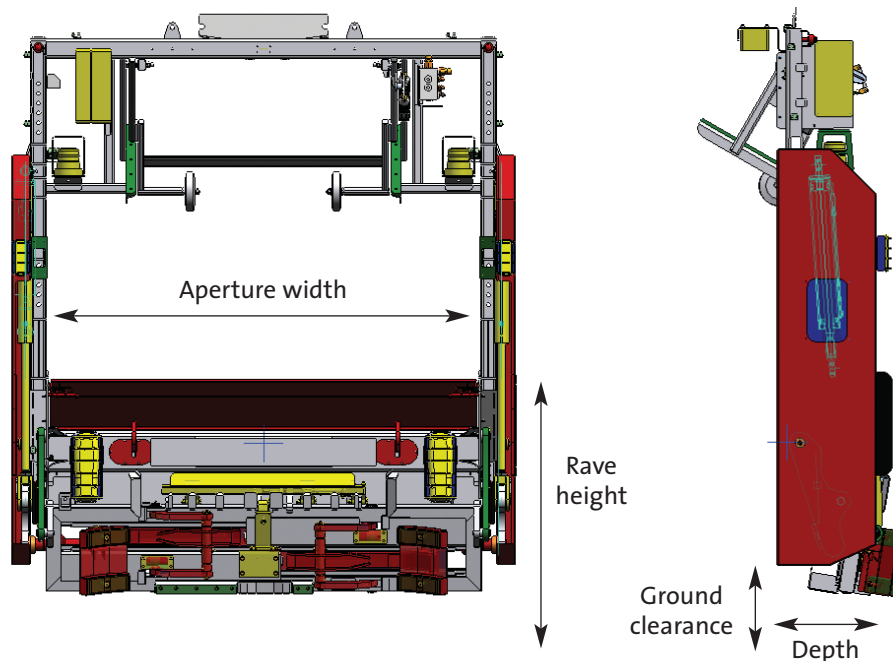

CONTAINER TYPES	WHEELED BIN	CONTAINER	CONTAINER	PALADIN
Container range	140/240 340 Litre	500/1200 Litre	770/1300 Litre	1.5 yd
Reference	EN840-1	EN840-2	EN840-3	

TECHNICAL DATA				
Cycle time	12 to 14 seconds including dwell time			
Operating pressure	180 bar (2650 psi)			
Lifting capacity	500 kgs			
Weight	Lip-lift only – 630 kgs approx. Paladin & Lip-lift – 670 kgs approx.			
Safety	CE Machinery Directive certification and EN1501-1 conformity			

KEY DIMENSIONS				
Ground clearance	Travelling position (fully raised)	450mm	Lift carriage down	295mm
Rave height	Raised position (one touch full cycle)	1400mm	Lowered position (hold to run controls)	1200mm
Loading aperture width	Narrow track (2250mm overall width)	1900mm	Wide track (2550mm overall width)	2200mm



DENNIS EAGLE LTD
DESIGNED WITH YOU IN MIND

Dennis Eagle Limited
Heathcote Way
Heathcote Industrial Estate
Warwick CV34 6TE
Tel: +44 (0)1926 458500
Fax: +44 (0)1926 316550
Email: sales@dennis-eagle.co.uk

www.dennis-eagle.co.uk